



# TECHNICAL SPECIFICATION OF TUG "TENAX"

**CP ASD Tug, with Ship Assist - Anchor Handling - Fi-Fi tug with Escort capability**

## Type of Vessel:

- CP ASD Tug, with Ship Assist
- Anchor Handling
- Fi-Fi tug with Escort capability.
- Oil Recovery Ship 1

## Classification:

ABS+A1, E, Escort Vessel, Towing Service, Fi-Fi 1, Oil Recovery Ship 1+AMS; ABCU, Unrestricted service

## Ship Details:

Flag: Italian  
Year Built: 08/2010  
IMO number: 9432995  
Call Sign: I I Y N 2  
MMSI: 247294900  
Cross Tons: 490 GT  
IMMARSST n°: 424703164 - 424703165  
MINI M n°: 00870765040756 - 00870765040757

## Dimensions:

LOA (Excluding Fenders): 32.00 m.  
Beam (Moulded): 12.00 m.  
Depth (Not including Skeg or Thruster): 5.36 m.  
Draft (Not including Skeg or Thruster): 4.312 m.  
Draft extreme: 5.880 m.

## Main Engines:

2 x Wartsila 8L26 Diesel Engines, 2400kW at 1000 rpm each, Resilient Mounted, Spark arrestor exhaust silencers, Box Cooler Cooled, Preheated, Full Automation, Electronic Governor Controlled.

## Gen.Sets:

Lindenberg, 2 x MAN D 2866 LXE, 245kW engine power, 120 kW electrical power each, Frant end driving towing winches.

## Harbour Gen.Set:

Perkins 4GM Stamford Alternator 40 kVa.

## Propulsion Units:

2\*RollsRoyce US 255, CP, with FireFighting System and Engine Load Control pre-programs and Back-up System.

## Propellers:

Counter Rotating, 2800 mm diameter, four Bladed Controlable Pitch, CuNiAl.

## Bow Thruster:

Mijosundet, Hydraulic operated, Bow thruster driven by stbd main-engine front end pto.

## Fire fighting:

Fi-Fi-1 Capacity with Deluge(sprey) System, Water & Foam.

## Speed

14 Knots ahead and astern minimum.





# TECHNICAL SPECIFICATION OF TUG "TENAX"

**CP ASD Tug, with Ship Assist - Anchor Handling - Fi-Fi tug with Escort capability**



## **Fore Towing Winch:**

70 Ton Pull, 85 Tons rendering at 19m/min, 200 tons Brake Power. Max. speed is 60m/min at 8 Tons pull. Capable of dynamic self tensioning up to 80 tons for escort operations. Brake Pressure can be adjusted. Tow Rope Tension and Tow Rope length indicators. Rope Length Alarm. 150 meter UHMWPE (Amstel Blue) rope.

## **Aft Towing Winch:**

Double Drum, 40 ton pulling at 21m/min, max speed is 64m/min at 8 Tons. 170 tonne brake capacity. Wire Length and Wire Tension Indicators. Wire Length Alarms. 2 x 950 meter certified towing wire with certified sockets.

## **Tugger Winch:**

Karmoy, 10 tons pull tugger winch, remote operated.

## **Fendering:**

Heavily fendered with 800x400 and 500x250 cylindrical fenders on bow and keyhole fenders all around the vessel

## **Stern Roller:**

1 meter diameter, 3 meter length, 131 tons SWL.

## **Tow pins:**

Karmoy Flush Towing pins with Karm Fork, remote operated

## **H-Bitt:**

Double H Bitt Type, Stainless Steel coated inside.

## **Aft Deck:**

Approx 5 ton/Sqm capacity with space for three 20 ft ISO Containers, Cargo Rails, Covered with wood

## **Communication:**

GMDSS A3, (Sailor) and Mini-M, Intercom and SP phone, VHF's remote operated

## **Navigation:**

Two Radars, GPS, Chart Plotter, Heading Sensor Based on DGPS, Magnetic Compass, Auto Pilot, Echo Sounder, (Simrad and Robertson), AIS, LRIT, Speed Log, Bridge Watch Alarm, General Emergency Alarm. Switchable fore and aft twin double navigational lights. Heated fore and aft windows, heated straightline wipers (8).

## **Automation:**

Unattended Engine room as per ABS ABCU Rules, Air conditioned Engine Monitoring Room, Remote Alarm panels with LCD Displays in Mess and Chief Engineer Cabin, and Extended operation of gensets and engine alarms from wheelhouse. Remote Start Stop of Engine Room Fans and Fire Pumps and Valves

## **Life Saving Equipment:**

3 Liferafts for 16 person + 12 life jackets + 8 life buoys + 2 MOB's + Line Throwers + pyrotechnics, immersion suits, thermal suits, escape sets, 4 fireman outfits etc. acc. to Solas and ABS.





# TECHNICAL SPECIFICATION OF TUG "TENAX"

CP ASD Tug, with Ship Assist - Anchor Handling - Fi-Fi tug with Escort capability

## **Solas Boat& Crane:**

Approved Solas Boat and Solas Crane. Crane has two lines, for the boat and cargo.

## **Deck Crane:**

Palfinger knuckle Boom Crahe of 1040 kg pull 10.3 meter outreach and 15 tonmeter moment. Wire Winch with 1.3 tons pull. Certified

## **Air conditioning:**

Fully airconditioried by Novenco Hi Press, Temperatures ISO standards and controlled independantly.

## **Water Maker:**

Hro Seafari 1400-2, 221 It/h

## **Oil Recovery:**

Vestjet HRF 440 S.steel pumps in each tank (6)

## **Tank Capacities:**

- Fuel oil (abt) = 190,080 litres
- Oil Recovery = 101,400 litres
- Fresh water = 37,000 litres
- Foam / Dispersant (P) = 17,400 litres
- Foam / Dispersant (S) = 17,400 litres
- Oily Waters = 1,200 litres
- Waste Oil (sludge) = 1,100 litres
- Sewage = 1,200 litres
- Engine Oil (hull tank) = 1,000 litres
- Overflow = 1,000 litres
- Thruster Lube Oil = 600 litres
- Towing Winch Oil = 800 litres
- Gen-Set Oil = 200 litres
- Bow Thruster Hydraulic Oil = 200 litres

## **Others:**

- Bilge Seperator, Ultra Sep :Fuel Seperator Westfalia
- Oil Seperator Westfalia with heater
- Water Treatment System-Holland Marine Services (1000litre/day)
- Vacuum Toilet — Jets 1SMB-D
- Compressors -2 x Sperre HL2/77
- Fresh Water Ultraviolet Filter System

## **BOLLARD PULL:**

85 tons minimum, 93 tons max.



# TECHNICAL SPECIFICATION OF TUG "TENAX"

CP ASD Tug, with Ship Assist - Anchor Handling - Fi-Fi tug with Escort capability





# TECHNICAL SPECIFICATION OF TUG "TENAX"

CP ASD Tug, with Ship Assist - Anchor Handling - Fi-Fi tug with Escort capability





# TECHNICAL SPECIFICATION OF TUG "TENAX"

CP ASD Tug, with Ship Assist - Anchor Handling - Fi-Fi tug with Escort capability

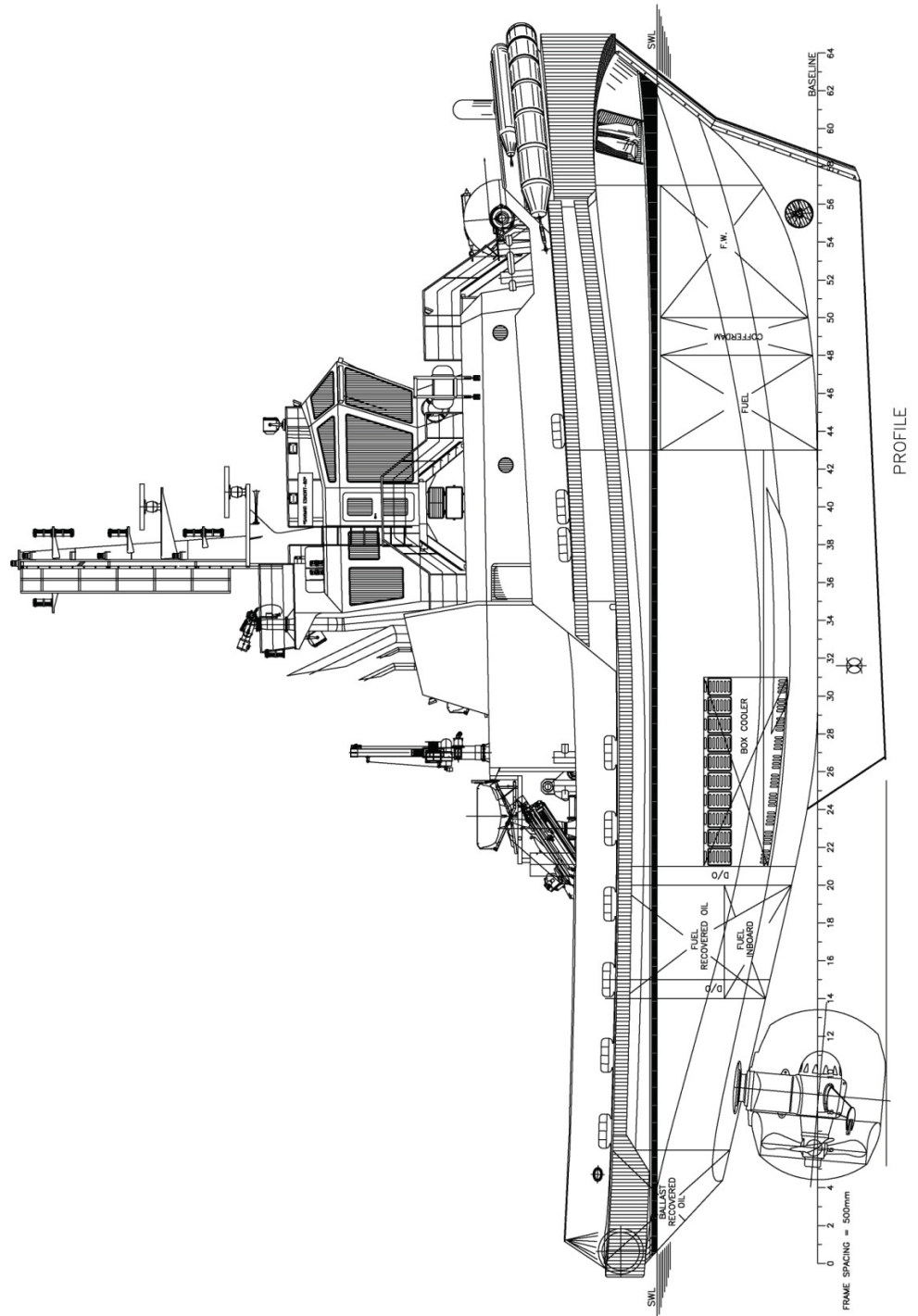





# TECHNICAL SPECIFICATION OF TUG "TENAX"

CP ASD Tug, with Ship Assist - Anchor Handling - Fi-Fi tug with Escort capability

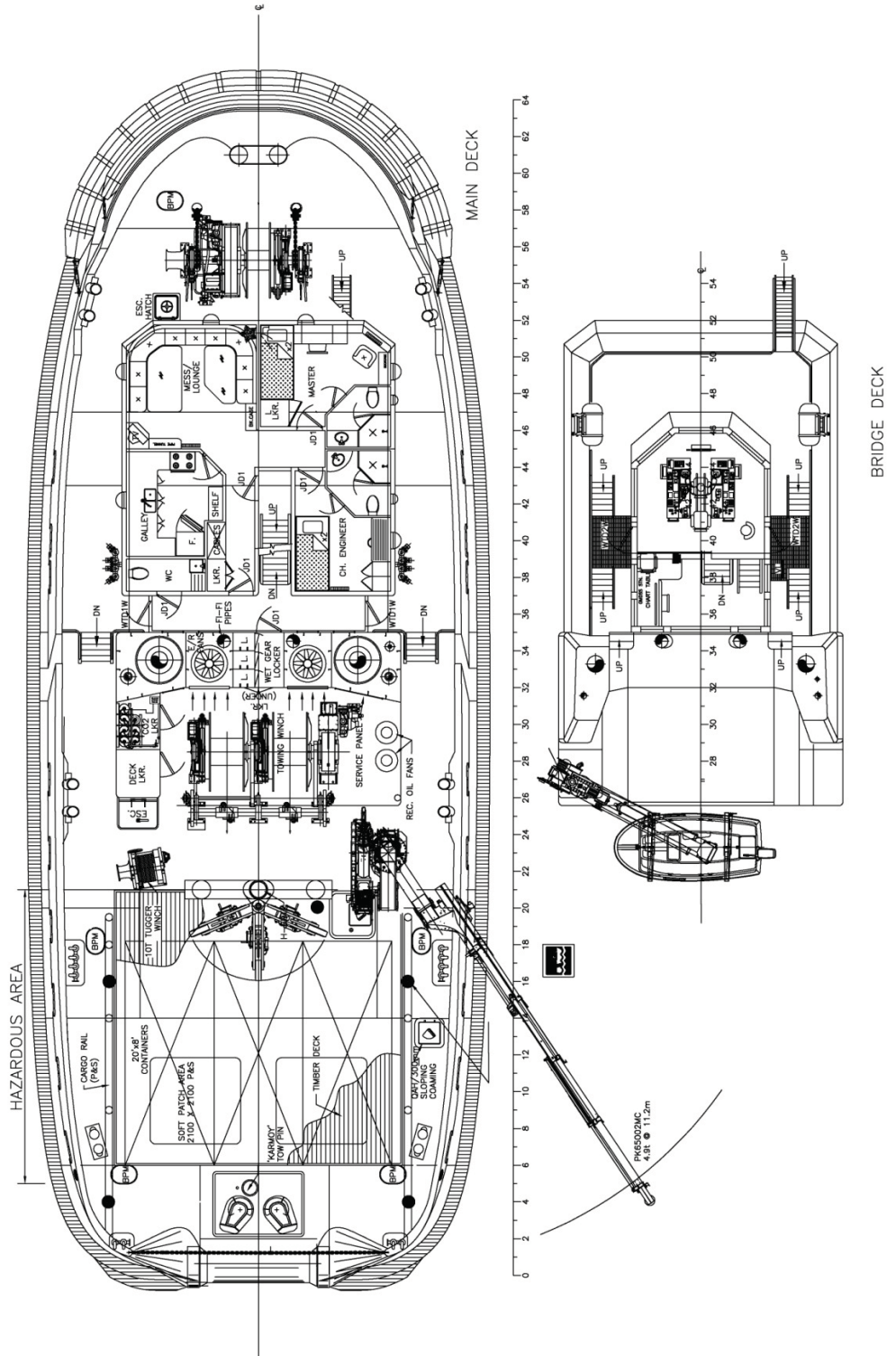





# TECHNICAL SPECIFICATION OF TUG "TENAX"

CP ASD Tug, with Ship Assist - Anchor Handling - Fi-Fi tug with Escort capability

